



2017 Subaru Mt Washington Hillclimb

Competition Classes & Safety Rules

All vehicles competing in the 2017 Subaru Mt. Washington Hillclimb must comply with the general safety rules listed in section 11, the restrictor rules in section 1 (if applicable) and the specifications appropriate to your class listed in sections 1 through 9.

Please note: If you have questions regarding the various class descriptions below or you have safety-related questions pertaining to the construction of your race car, please call Don Taylor at his shop (603) 542-8549 or on his cell phone at (603) 543-7456 *before* you complete your Entry Application. Don is the Chief Technical Inspector for the 2017 Subaru Mt. Washington Hillclimb and will be able to answer all Class & Safety-related questions pertaining to your race car.

Competition Classes

Unlimited
Open
Prepared
High Performance Showroom Stock
Global Rally Cross
Rally
Vintage
Modified Electric
Stock Electric

Designations

U
O
P1, P2 & P3
HPSS
GRC
R1 & R2
V
ME
SE

Definitions

2WD – Two Wheel Drive
ARA – American Rally Association
AWD – All wheel drive, includes four wheel drive
CARS – Canadian Association of Rally Sport
CFM – cubic feet per minute
ECM – Engine Control Module
FIA – Fédération Internationale de l'Automobile
Free – free to do as you want in the related area
GRC – Global Rally Cross

MSDS – Material Safety Data Sheets
NHRA – National Hot Rod Association
OBD – On Board Diagnostics
RA – Rally America
SCCNH – Sports Car Club of New Hampshire
SDS – Safety Data Sheets
SFI – SFI Foundation Inc.
VSCCA – Vintage Sports Car Club of America

1. General Vehicle Rules

These rules apply to all vehicles

- 1.1. Catalytic converters are not required
 - 1.2. Tire size and type is free in all classes
 - 1.3. Restrictors

The classes that require restrictors fall under the following guidelines for the size and location of the restrictor.

 - 1.4. All intake air must pass through the restrictor.
 - 1.5. Turbos: Restrictor can be no further than 50mm from the turbo impeller.
 - 1.6. Superchargers: Restrictor must be as close as possible to the supercharger body.
 - 1.7. GRC – 45 mm restrictor, dimensions and location determined by GRC rules
 - 1.8. Rally classes – 34 mm restrictor, dimensions and location determined by ARA, RA or CARS rules.
 - 1.9. 2WD drive forced inducted cars do not require a restrictor
 - 1.10. All other forced induced classes that require a restrictor
 - 1.10.1. All restrictors must maintain their maximum diameter for a minimum of 3mm and be on the intake of the forced induction device.
 - 1.10.2. A 1995 or older vehicle, OBD 1 with stock non-socketed ECM not capable of being reprogrammed shall have a 50mm or smaller restrictor
 - 1.10.3. A 1996 or newer, OBD 2 stock ECM must have a 40mm or smaller restrictor
 - 1.10.4. Programming stock ECM is allowed on OBD 2 vehicles
 - 1.10.5. Twin turbo cars must have a 28.8 mm restrictor for each turbocharger
 - 1.10.6. If a newer engine OBD2 is installed in an OBD 1 vehicle, it must have a 40mm restrictor, and may run a stock OBD2 ECM that may be reprogrammed.
 - 1.10.7. Prepared 1 class cars require a 40mm restrictor if the vehicle is AWD and the motor is forced induced.
-

2. Unlimited

Class Designator: U

This class is for purpose build or heavily modified cars, 2WD or AWD. They may be open wheeled or full bodied using composite, metal or other approved materials.

- 2.1. There are no restrictions on motor size.
 - 2.1.1. Forced induction is allowed.
 - 2.1.2. No restrictors are required.
 - 2.2. There are no restrictions on vehicle weight.
 - 2.3. These vehicles may have custom made frames and bodies.
 - 2.3.1. All frames must be of good quality design and fabrication or they will not pass technical inspection. If you have questions on accepted materials and design then check with Chief of Tech.
 - 2.4. The driver of the vehicle shall be seated between the front and rear axles.
 - 2.5. This class requires roll cage A.
-

3. Open

Class Designator: O

This class is for open wheel and closed body cars made specifically for racing, 2WD or AWD. They may be custom made including frames and running gear.

- 3.1. Allowed motors
 - 3.1.1. Naturally aspirated motors up to 7 liters allowed.
 - 3.1.2. Forced induction motors up to 3.5 liters are allowed, restrictor required if AWD.
 - 3.2. There are no restrictions on vehicle weight.
 - 3.3. These vehicles may have custom made frames and bodies.
 - 3.3.1. All frames must be of good quality design and fabrication or they will not pass technical inspection. If you have questions on accepted materials and design then check with Chief of Tech.
 - 3.4. The driver of the vehicle shall be seated between the front and rear axles.
 - 3.5. This class requires roll cage B.
-

4. Prepared

This class is for production based cars that were available to the general public with more than 500 produced by a recognized manufacturer.

- 4.1. Body shall remain recognizable as its model.
 - 4.1.1. Most all of stock flooring must remain in place, no tube frames.
 - 4.1.2. Body flares and wings are allowed.
 - 4.1.3. All original body panels must remain the same as the original in shape but may be made from alternate materials.
 - 4.1.4. All motor modifications are allowed.
 - 4.1.5. Windshield must be OEM or a replacement OEM.
 - 4.1.6. Side and rear windows may be Lexan of a minimum of 3mm thick. Side windows are not required.
 - 4.1.7. The interior may have all unnecessary items removed to further lighten the vehicle.
 - 4.2. A restrictor is required if the vehicle is AWD or 4WD and the motor is forced induced.
 - 4.3. Fuel injection system is free.
 - 4.4. Transmission is free.
 - 4.5. Differentials are free.
 - 4.6. This class requires roll cage B.
 - 4.7. There are 3 subclasses, the differences are listed below.
 - 4.7.1. Prepared 1 class** **Class Designator: P1**
 - 4.7.1.1. AWD
 - 4.7.1.2. 2.5 liters or below forced induced or
 - 4.7.1.3. 3.5 liters or below naturally aspirated
 - 4.7.2. Prepared 2 class** **Class Designator: P2**
 - 4.7.2.1. 2WD
 - 4.7.2.2. 2.5 liters or below with forced induction or
 - 4.7.2.3. 6 liters or below naturally aspirated
 - 4.7.3. Prepared 3 class** **Class Designator: P3**
 - 4.7.3.1. 2WD or AWD
 - 4.7.3.2. 2.5 liters or below naturally aspirated.
-

5. High Performance Showroom Stock Class Designator: HPSS

This class is for AWD production based cars that were available to the general public with more than 500 produced by a recognized manufacturer. The car must appear to be stock.

- 5.1. Minimum weight of vehicle is 3000 lbs.
 - 5.2. Motor must be 2.5 liters or smaller and must remain stock as delivered from the manufacturer.
 - 5.2.1. Cylinders may be over bored up to 0.030 of an inch.
 - 5.2.2. Rods and pistons may be replaced but must remain in stock dimensions. Stock compression must be maintained.
 - 5.2.3. This class requires a restrictor if the motor is forced induced.
 - 5.2.4. The installed forced induction device, exhaust manifold, and intake manifold must be from the manufacturer for that engine and cannot be modified. No factory performance or aftermarket performance forced induction device or manifolds allowed.
 - 5.2.5. Fuel injectors are free.
 - 5.2.6. Water or methanol injection is not allowed
 - 5.2.7. ECU must remain stock
 - 5.3. Transmission and differentials must all remain stock as delivered from the manufacturer
 - 5.4. Suspension
 - 5.4.1. Anti-sway bar is free but must use the stock mounts
 - 5.4.2. Shocks and springs are free but must use the original mounting points
 - 5.4.3. Poly bushings may be used
 - 5.5. Body
 - 5.5.1. All stock glass must remain
 - 5.5.2. All body panels must remain stock
 - 5.5.3. Wings and spoilers must remain stock
 - 5.5.4. Fender flairs are allowed
 - 5.5.5. Stock lighting must remain in place
 - 5.6. Allowed removal of items
 - 5.6.1. Interior must remain intact except the following may be removed
 - 5.6.1.1. Interior carpet and headliner
 - 5.6.1.2. Air conditioning
 - 5.6.1.3. Stock passenger seat may be replaced with racing seat.
 - 5.6.1.4. Entertainment unit including speakers
 - 5.6.1.5. Navigation unit
 - 5.6.2. Interior trim in the trunk or hatch area as long as it is behind rear seat
 - 5.6.3. Jack, spare tire and tools
 - 5.6.4. Under hood insulation
 - 5.7. Battery size is free
 - 5.8. Wheels are free
 - 5.9. This class requires roll cage B
-

6. GRC

Class Designator: GRC

This class is for Global Rallycross cars

- 6.1. These cars must fit the rules and specifications of the rule book for these vehicles. The specifications for those cars are on The Global Rallycross webpage.
 - 6.2. This class requires a FIA homologated cage, or FIA 253 J specification cage with gussets as shown in roll cage A. Homologated cage runs as designed.
-

7. Rally

This class is for rally cars as defined by ARA, RA, NASA, SCCA or CARS

- 7.1. All cars must be log booked and fit the 2017 ARA, 2016 RA or CARS rules.
- 7.2. Driver and Co-driver are required.
- 7.3. These classes require roll cage A or FIA homologated cages run as designed.
- 7.4. There are 2 subclasses

7.4.1. Rally 1 class

Class Designator: R1

- 7.4.1.1. This class is for AWD Rally cars

7.4.2. Rally 2 class

Class Designator: R2

- 7.4.2.1. This class is for 2WD Rally cars
-

8. Vintage Class

Class Designator: V

Participation in this class is by invitation only. Cars competing in this class must comply with current VSCCA safety requirements.

9. Modified Electric

Class Designator: ME

This class is for electric cars made for, or modified for, racing.

- 9.1. Electric specific
 - 9.1.1. The vehicle must be totally powered by battery power, no other fuel may be used.
 - 9.1.2. All batteries must be fully contained in enclosures that may be sealed by race tech officials.
 - 9.1.3. A forced battery ventilation system must be fitted and must be rated at least 10 cfm.
 - 9.1.4. An MSDS or SDS sheet and a least 5 copies of the information must be presented for safety and tech officials.
 - 9.1.5. Any electric cables in the system must be the proper size to safely carry the current from the batteries without overheating.
 - 9.1.6. Any conductor or non insulated area that is exposed must be properly insulated and labeled as high voltage with proper warning signs.
 - 9.1.7. A fuse, not a circuit breaker, must be in series with the main power source and cannot exceed 200 % of the expected battery draw at full load of system.
 - 9.1.8. Vehicle must have a master disconnect switch that will completely disconnect the vehicle from the power source.
 - 9.1.8.1. This switch must be clearly marked for both on and off positions.
 - 9.1.8.2. This switch must be accessible by the driver and safety personnel from outside the vehicle.
 - 9.2. The vehicle must be fitted with an audible warning that operates whenever the vehicle is moving and must be 110 decibels or louder. The activation of this device must only be accessible from outside the vehicle.
 - 9.3. There are no restrictions on vehicle weight.
 - 9.4. These vehicles may have custom made frames and bodies.
 - 9.4.1. All frames must be of good quality design and fabrication or they will not pass technical inspection. If you have questions on accepted materials and design then check with Chief of Tech.
 - 9.5. The driver of the vehicle shall be seated between the front and rear axles.
 - 9.6. All flywheels must be covered with an NHRA approved scatter shield/blanket and labeled with proper SFI label.
 - 9.7. The driver must be shielded from any other rotating parts.
 - 9.8. This class requires roll cage A.
-

10. Stock Electric

Class Designator: SE

This class is for production electric vehicles and they must be run as manufactured.

- 10.1. No hybrid vehicles will be allowed, vehicle must operate totally on electricity, no other fuel may be used.
 - 10.2. No modification to the vehicle is allowed except for the safety changes listed below.
 - 10.3. The vehicle must be fitted with an audible warning that operates whenever the vehicle is moving and must be 110 decibels or louder. The activation of this device must only be accessible from outside the vehicle.
 - 10.4. All flywheels must be covered with an NHRA approved scatter shield/blanket and labeled with proper SFI label.
 - 10.5. The driver must be shielded from any other rotating parts.
 - 10.6. This class requires roll cage B.
-

11. Safety Rules

All vehicles must comply with these safety rules

- 11.1. All vehicles must pass a tech inspection at the event. All vehicles must be safe. All items will not be listed here. Any vehicle found unsafe for any reason will not be allowed on the course.
- 11.2. 5lbs of portable fire suppression, it maybe in one or two units mounted with a steel bracket. A fire system may also be used but the portable units are still required.
- 11.3. SFI or FIA Window nets or SFI or FIA arm restraints for each occupant.
- 11.4. 5 or 6 point restraint system with an SFI date no older than 2 years. FIA systems will go by expiration date.
- 11.5. Brake systems must be true two circuit systems so if one circuit fails the other will work. Must have two separate reservoirs unless you are using a factory stock dual circuit system.
- 11.6. Fuel
 - 11.6.1. Any non stock fuel tank must be an approved fuel cell. All fuel systems shall be bulkheaded to protect the occupant.
 - 11.6.2. Any fuel system components in the same enclosure as occupant, not bulkheaded, must be of metal including lines, pumps and regulators.
 - 11.6.3. All fuel pumps must shut off automatically if the car stalls.
 - 11.6.4. Nitrous oxide is not permitted.
 - 11.6.5. Any methanol, even if mixed with water, falls under same rules as gasoline.
 - 11.6.6. Any open cars shall have panels in place to protect the occupant(s) in case of off road incident from external intrusions including from fluids from the engine. Both engine cover and side panels are required.
 - 11.6.7. Tires may not be showing any delamination or cord.
 - 11.6.8. Suspension must be tight, no looseness.
 - 11.6.8.1. Any heim style joints used in the suspension of the vehicle must be safety washered in case of joint failure, no complete separation can occur.
 - 11.6.9. Plexiglass will not be allowed, custom made window material must be made from Lexan.
 - 11.6.10. All vehicles must have a one piece racing seat for the occupants. If it is not FIA approved it must have a back brace or be up against roll cage structure, no plastic seats will be allowed.
 - 11.6.11. Unlimited and the open classes shall have a battery shut off switch accessible from outside the vehicle and by the occupant.
 - 11.6.12. Batteries and cables must be a safe distance from fuel.
 - 11.6.13. Any battery inside of occupant area must be sealed in a marine battery box and properly mounted.
- 11.7. All vehicles must have a roll cage complying with the following. Each class description noted which cage must be used.

11.7.5. Roll cage B

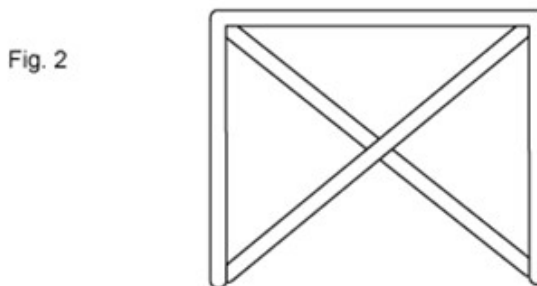
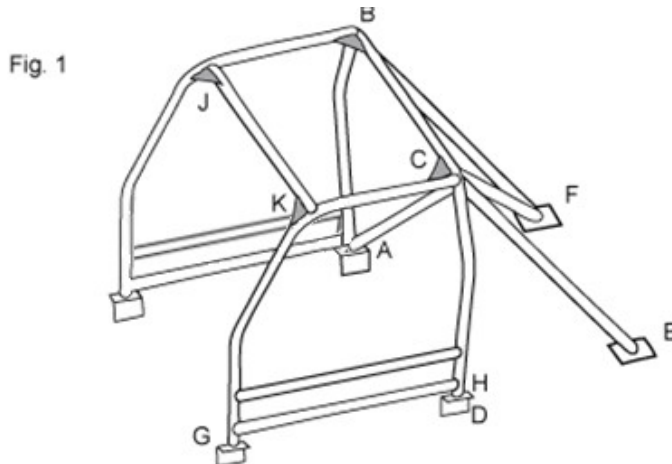

- 11.7.5.1. This diagram is for a full sized vehicle., Two side bars are required on both sides of the cage. This diagram is minimum requirement, extra tubing is allowed as long as the pictured elements are present.
- 11.7.5.2. The top four corners require gussets as pictured in Fig. 1, they may be flat gussets or tubing gussets.
- 11.7.5.3. Lower side bar is considered a sill bar and must be no further than 6 inches off floor.
- 11.7.5.4. The main hoop may have one diagonal with opposing diagonal in the aft supports or an X in the main hoop eliminating the need for an aft diagonal support.
- 11.7.5.5. Making the side bars an X configuration is allowed. Sill bar is still required.

11.8. Vehicle occupants must comply with the following

- 11.8.1. Helmet: SA2010 or SA2015 or, FIA or British standard as long as the manufacture date is in place and the helmet is not more than 10 years old.
- 11.8.2. Any vehicle without a windshield must use a full face approved helmet with full face shield.

- 11.8.3. All occupants must wear an approved FIA or SFI head and neck restraint system
- 11.8.4. Driving suit must be SFI rated 32A1 with fireproof underwear or SFI 32A5 (fireproof underwear not necessary) or FIA.
- 11.8.5. FIA or SFI fire resistant gloves, shoes and balaclava for facial hair are required.

Entrant should watch the website for any bulletins that may amend these rules

Website: <http://climbtothecLOUDS.com/>

Register at: <http://msreg.com/2017CTTC>